



Cushion-Mount™

1920M Cushion-Mount Plus Plate Mounting System

Product Data Sheet

Updated : June 1998 (1st Issue)
Supersedes :

Product Description 1920M Cushion-Mount Plus is a double coated low-medium density polyethylene foam tape with acrylic adhesive on each side of the carrier.

Physical Properties
Not for specification purposes

Adhesive Type	Differential Acrylates	3M ref :
Foam (colour)	Polyethylene (pink)	
Thickness (ASTM D-3652) Tape Liner Total	0.56 mm 0.10 mm 0.66 mm	
Tolerance Between 25yd (22.9m) rolls In 1 square yd (0.84m ²) piece	± 0.038 mm ± 0.011 mm	
Shelf Life	12 months from date of despatch by 3M when stored in the original carton at 21°C (70°F) & 50% Relative Humidity	

Performance Characteristics
Not for specification purposes

Density	Low-Medium	
Type of Printing	Combination of solids & process	
Type of Plate	Photopolymer	
Peel Adhesion	Stainless Steel Composite Sleeve Photopolymer	2.2 N/10 mm N/A 3.3 N/10 mm
Shear Static ASTM D-3654 Value - weight held for 10,000 minutes.	Room Temp 70°C	500 gms 250 gms
Solvent Resistance	Water - Excellent Alcohols - Good	Alkanes - Excellent Acetates - Fair
Heat Resistance	150°F (65°C)	

Date : June 1998
1920M Cushion-Mount Plus
Plate Mounting System

Mounting & Removal Techniques

Cylinders, sleeves and plates should be clean and dry before tape is applied. Removal of dirt, oils, residual inks and general contaminants from the cylinder and plate surfaces is important in developing optimum adhesion results. A thorough wash using a 50:50 mixture of Isopropanol and water should be sufficient for cleaning cylinders, sleeves and plates, unless there is a significant build up of grease, oils, ink or other contaminants. A mild solvent should be used to cut the grease, oil or ink build-up and then followed by a wash with a 50:50 mixture of Isopropanol and water. **NOTE: When using solvents be sure the follow the manufacturer's directions and precautions for handling such materials.**

Surface uniformity is important in developing consistent adhesion across the entire cylinder and plate. Scratches, nicks, dents and other surface abnormalities will create variation in adhesion levels. This variation may result in removability or flagging problems. Care and effort should be taken in maintaining a consistent uniform cylinder surface.

If plate removal is a problem due to high adhesion, a coating may be used on the back of the plate to facilitate clean removal. A 50:50 mixture of wood shellac and alcohol or a 50:50 mixture of ink extender and alcohol are common coatings that help reduce adhesion. This technique may be needed when working with ground rubber plates where the grinding operation increases adhesion or with use of thin or low durometer photopolymer plates.

After the tape and plate have been bonded to the cylinder or sleeve a thin poly film should be tightly wrapped around the whole system. Wrapping of the tape/plate/cylinder system helps reduce stress on the tape/plate bond by holding the plate against the tape and alleviating the stress induced by the plate's memory to return to its original flat geometry. Wrapping of the system enables the plate/tape bond to build to its optimum level without the stress of the plate memory working against the tape/plate adhesion bond. The cylinder should remain wrapped until it is installed in the press.

The total tape area used should exceed the size of the plate by a minimum of 0.5 inches (12.7 mm) around the perimeter of the plate. Using excess tape will help disperse the stress of plate memory and minimise plate lifting.

Edge sealants may be used to eliminate inks and other solvents from migrating between the tape and plate and causing plate lifting during the press operation. This becomes more important during long press runs where plates are cleaned during the press run.

Upon removal of the plate/tape system from the cylinder or sleeve, the plate should be removed from the tape then the tape removed from the cylinder or sleeve. When removing the plate or tape a "low & slow" technique should be used. A slow rate of speed at a low angle, less than 45 degrees, is optimum. This will help ensure clean removal of the tape and plate.

Date : June 1998
1920M Cushion-Mount Plus
Plate Mounting System

Cylinder Removal

In order to remove the tape cleanly from the cylinder and eliminate the time consuming job of cleaning adhesive residue from the cylinder, a **low angle slow peel technique** should be used to remove the tape from the cylinder. The tape should be lifted off the cylinder slowly, maintaining a peel off angle of less than 45° from the plate cylinder (see Diagram 1). This will significantly reduce the chance of adhesive residue remaining in the plate cylinder.

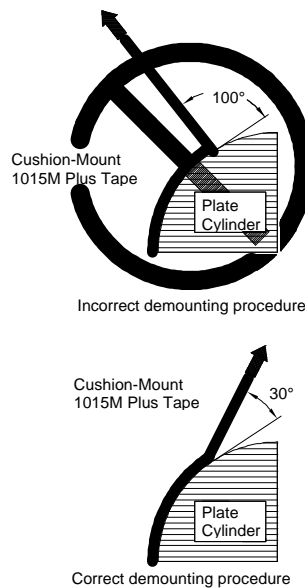

3M has developed this product to help improve flexographic print quality. To successfully use this product and improve your print quality a little more care and time is needed to handle and remove this product. This is due to the product's soft, more resilient foam which is needed to help produce your high quality process printing.

Application Ideas

Cushion-Mount Plus tapes are designed for mounting photopolymer flexographic printing plates to flexographic plate cylinders and sleeve systems. The products range in thicknesses in order to meet undercut or pitch diameters that are common to flexographic printing presses.

The adhesive systems on each tape have been developed for bonding to photopolymer printing plates.

Tapes are developed to be used for photopolymer only (except 1020R - rubber only), since the composition and backside surface of these two plates are extremely different.

All the Cushion-Mount Plus products have differential adhesives. Due to the differential adhesives these products should be mounted cylinder first.

The foam carriers are designed for specific types of printing.

The low density Cushion-Mount Plus tapes (11 series) are designed for high quality process printing.

The low-medium density Cushion-Mount Plus tapes (19 series) are designed for combination printing including more process and highlight areas.

The medium density Cushion-Mount Plus tapes (10 series) are designed for a combination of process or tone reproduction in conjunction with solids printing.

The high-medium density Cushion-Mount Plus tapes (18 series) are designed for combination printing including more solid and dark halftone areas.

3M and Cushion-Mount are trademarks of the 3M Company.

Values presented have been determined by standard test methods and are average values not to be used for specification purposes. Our recommendations on the use of our products are based on tests believed to be reliable but we would ask that you conduct your own tests to determine their suitability for your applications. This is because 3M cannot accept any responsibility or liability direct or consequential for loss or damage caused as a result of our recommendations.

3M

Tapes & Adhesives

3M United Kingdom PLC
3M House,
28 Great Jackson Street,
Manchester,
M15 4PA

Customer Service :
Tel [3MUKP1]0161 236 8500
Fax 0161 237 1105

3M Ireland
3M House, Adelphi Centre,
Upper Georges Street,
Dun Laoghaire, Co. Dublin,
Ireland

Customer Service :
Tel (01) 280 3555
Fax (01) 280 3509

© 3M United Kingdom PLC 1998

